

# Oxymac50, DE800 and Elecdit

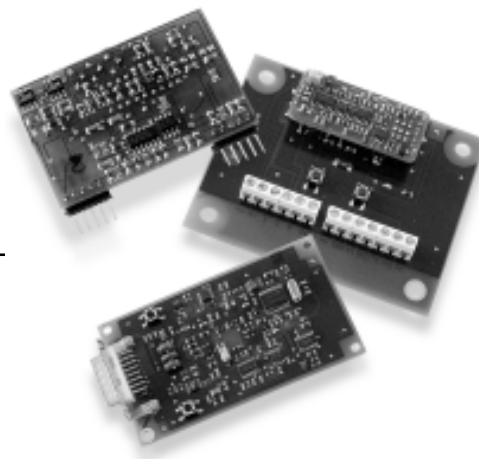

## Oxygen Sensor Interface Boards Accurate oxygen measurement

### DESCRIPTION

The Oxymac 50, Elecdit and DE800 sensor interface boards are control and measurement devices for Honeywell's range of dynamic highly accurate oxygen sensors. The ability of these sensors to operate without any reference gas makes them ideal for many applications including combustion and environmental control.

Honeywell oxygen sensors using zirconia based sensing elements require external connection to an electronic measuring circuit to control sensor operation and signal processing. A heating element on the sensor produces the 700 °C required for the ZrO<sub>2</sub> to achieve its operational temperature. These interface boards supply the sensor with the necessary circuits to provide this control and processing, while also providing sensor calibration. The DE800 interface also includes the heater supply, Oxymac50 and Elecdit require an external heater power supply .

### FEATURES

- Provides the necessary circuits to control Honeywell oxygen sensors
- Functional testing and calibration in ambient air
- PCB board format
- Linear output of measured oxygen content in voltage or current format
- Low power consumption

### TYPICAL APPLICATIONS

- Heating boiler control
- Industrial process control
- Combustion systems
- Compost systems
- Environmental control
- Medical
- Aerospace

Oxymac50 is a recently upgraded interface that offers similar performance to the Elecdit board but operates from a 24 Vdc power supply.

The DE800 interface offers the features of the Oxymac50 but also contains the heating element power source.

The Elecdit interface was developed for Industrial applications and offers a level of noise protection. It operates from a ±15 V supply.

Oxymac50 and DE800 are the recommended interfaces for new applications.

The interfaces are supplied ready for mounting into customers' enclosures. Oxymac50 a 15-pin D type connector, DE800 has screw connector block and Elecdit has 2,5 mm x 2,5 mm (0.1 in x 0.1 in) pin connector.

### BENEFITS

- Removes the need to implement sensor control circuits within customers' equipment
- Removes effects of barometric or application pressure changes and sensor drift for best accuracy
- Ease of mounting and access for calibration
- Flexible interconnection
- Lower running costs

# Oxymac50, DE800 and Elecdit

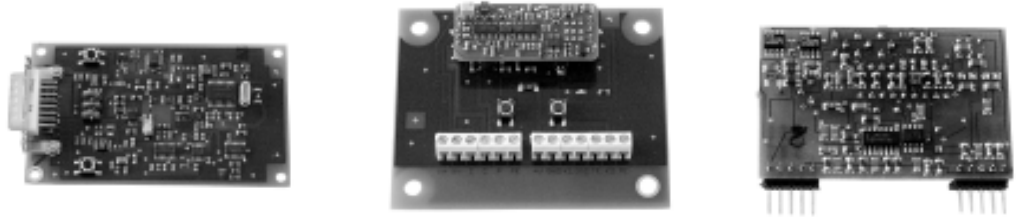

## TECHNICAL DATA

	Oxymac50	DE800	Elecdit
Measuring range		0 % to 25 % oxygen (standard) 0 % to 100 % oxygen (option)	
Power source	+24 Vdc $\pm$ 20 %	+24 Vdc $\pm$ 20 %	$\pm$ 15 Vdc $\pm$ 10 %
Other inputs	Ext Calibration, Sensor Pump, Sense and Common, Test	Ext Calibration, Sensor Pump, Sense, Common, Heater, Test	Ext Calibration, Sensor Pump, Sense and Common
Power consumption (interface)	<250 mW	<500 mW	<250 mW
Outputs	0 V to 10 V, 4 mA to 20 mA <sup>(1)</sup>	4 mA to 20 mA, 0 V to 10 V <sup>(1)</sup> , Pulse	0 V to 10 V, LED drive
Accuracy	2 % full scale		
Resolution	0.04 V		
Operating temperature	-10 °C to 60 °C		
Storage temperature	-10 °C to 50 °C		
Dimensions	63 mm x 108 mm, 4 mm $\varnothing$ mounting holes	80 mm x 100 mm, 6,5 mm $\varnothing$ mounting holes	60 mm x 42 mm x 17 mm
Connector	15 pin male D connector	Screw connector block	2 x 5 pin 2,5 mm x 2,5mm
Mates with type	GMS-10, KGZ-10, KGZ-12		

Notes: For warm up time and other sensor characteristics refer to datasheet 100470-EN

<sup>(1)</sup> Factory set to voltage or current output

## OPERATING AND CALIBRATION NOTES

### Oxymac50

1. Reset of the Oxymac50 is possible by putting the power off/on.
2. The output signal can be 0 V to 10 V or 4 mA to 20 mA. The output signal is factory set by the solder bridge JP1.
3. A proper operation of a connected sensor and electronic circuit can be tested with the test switch or with an external signal. After switching the test function the output signal should indicate a 20 % lower value.
4. LED indication - proper sensor operation is indicated by blinking of LED D3.
5. Calibration - sensor and Oxymac circuit can be calibrated in normal air. After a loss of power the Oxymac50 circuit stores the calibration value.

### DE800

1. Heater adjustment - the heater voltage of the sensor can be adjusted with pot meter PC419.
2. Test function - after pressing the test button, the output has to go to a 20% lower output signal. Testing with an external (24 V) signal is possible via terminal TE.
3. Calibration - the sensor can be calibrated in normal air with the calibration button. Calibration is lost after power loss.
4. LED - if the sensor is functioning properly, the LED D4 is blinking.
5. Signal out - if the sensor is functioning properly a pulse signal can be measured at terminal K2.

### Elecdit

Adjustment/calibration procedure. *The interface is factory set, for sensor replacement follow these instructions.*

1. Adjust with Pot1 12 V (internal  $\pm$ 6 V) at Pin 2.
2. Adjust with Pot2 reference at Pin 1 to 10 V  $\pm$ 0.2 V.
3. After approx 60 s an impulse (blinking) signal should be present at Pin 1. Apply at the sensor 95 mbar air, adjust with Pot5 at Pin 9 to 0.8 V. Then apply at the sensor 1013 mbar air and adjust with Pot3 at Pin 9 Uout to 8.3 V.
4. Adjust with Pot4 0 mV at Pin 10.
5. Adjust with Pot5 Uout to 0 V at Pin 9.

# Oxygen Sensor Interface Boards

## MOUNTING DRAWINGS, FOR REFERENCE ONLY

### OXYMAC50

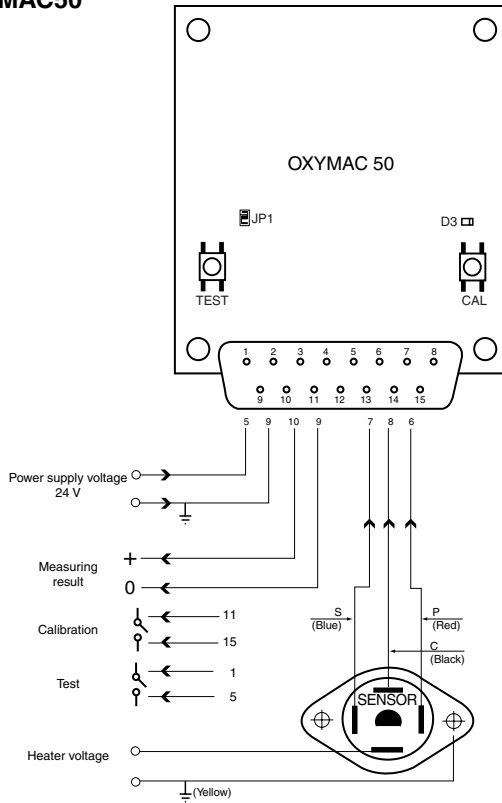

### DE800

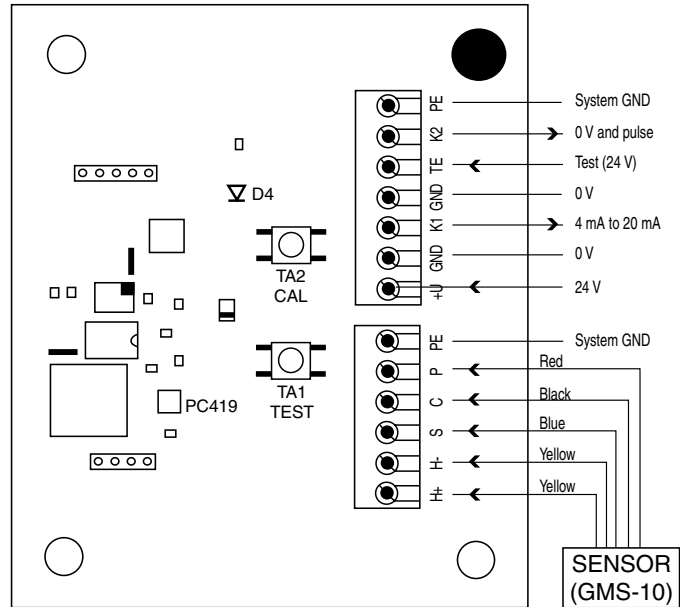

### ELECDIT

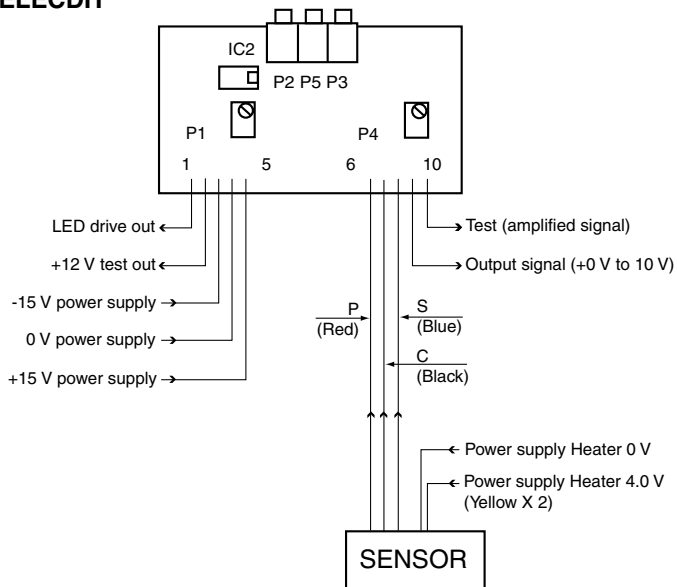

## ORDER GUIDE

Oxymac 50.V.1	Oxymac50 circuit, output 0 V to 10V, measuring range 0 % to 25 %
Oxymac 50.V.2	Oxymac50 circuit, output 0 V to 10V, measuring range 0 % to 100 %
Oxymac 50.A.1	Oxymac50 circuit, output 4 mA to 20mA, measuring range 0 % to 25 %
Oxymac 50.A.2	Oxymac50 circuit, output 4 mA to 20mA, measuring range 0 % to 100 %
DE800.V.1	DE800 circuit, output 0 V to 10V, measuring range 0 % to 25 %
DE800.V.2	DE800 circuit, output 0 V to 10V, measuring range 0 % to 100 %
DE800.A.1	DE800 circuit, output 4 mA to 20mA, measuring range 0 % to 25 %
DE800.A.2	DE800 circuit, output 4 mA to 20mA, measuring range 0 % to 100 %
Elecdit.V.1	Elecdit circuit, output 0 V to 10V, measuring range 0 % to 25 %
Elecdit.V.2	Elecdit circuit, output 0 V to 10V, measuring range 0 % to 100 %

**⚠ WARNING**  
**MISUSE OF DOCUMENTATION**

- The information presented in this product sheet is for reference only. Do not use this document as a product installation guide.
- Complete installation, operation, and maintenance information is provided in the instructions supplied with each product.

**Failure to comply with these instructions could result in death or serious injury.**

**⚠ WARNING**  
**PERSONAL INJURY**

DO NOT USE these products as safety or emergency stop devices or in any other application where failure of the product could result in personal injury.

**Failure to comply with these instructions could result in death or serious injury.**

### WARRANTY/REMEDY

Honeywell warrants goods of its manufacture as being free of defective materials and faulty workmanship. Honeywell's standard product warranty applies unless agreed to otherwise by Honeywell in writing; please refer to your order acknowledgement or consult your local sales office for specific warranty details. If warranted goods are returned to Honeywell during the period of coverage, Honeywell will repair or replace, at its option, without charge those items it finds defective. **The foregoing is buyer's sole remedy and is in lieu of all warranties, expressed or implied, including those of merchantability and fitness for a particular purpose. In no event shall Honeywell be liable for consequential, special, or indirect damages.**

While we provide application assistance personally, through our literature and the Honeywell web site, it is up to the customer to determine the suitability of the product in the application.

Specifications may change without notice. The information we supply is believed to be accurate and reliable as of this printing. However, we assume no responsibility for its use.

### SALES AND SERVICE

Honeywell serves its customers through a worldwide network of sales offices, representatives and distributors. For application assistance, current specifications, pricing or name of the nearest Authorized Distributor, contact your local sales office or:

**E-mail:** [info.sc@honeywell.com](mailto:info.sc@honeywell.com)

**Internet:** [www.honeywell.com/sensing](http://www.honeywell.com/sensing)

#### Phone and Fax:

Asia Pacific	+65 6355-2828
	+65 6445-3033 Fax
Europe	+44 (0) 1698 481481
	+44 (0) 1698 481676 Fax
Latin America	+1-305-805-8188
	+1-305-883-8257 Fax
USA/Canada	+1-800-537-6945
	+1-815-235-6847
	+1-815-235-6545 Fax

### Automation and Control Solutions

Sensing and Control

Honeywell

Newhouse Industrial Estate

Motherwell, ML1 5SB, UK

[www.honeywell.com](http://www.honeywell.com)

100480-EN UK07 GLO  
May 2005  
Copyright 2005 Honeywell International Inc.

# Honeywell